

CROWN

SC 5200 SERIES

Specifications

Sit-Down Rider Lift Truck



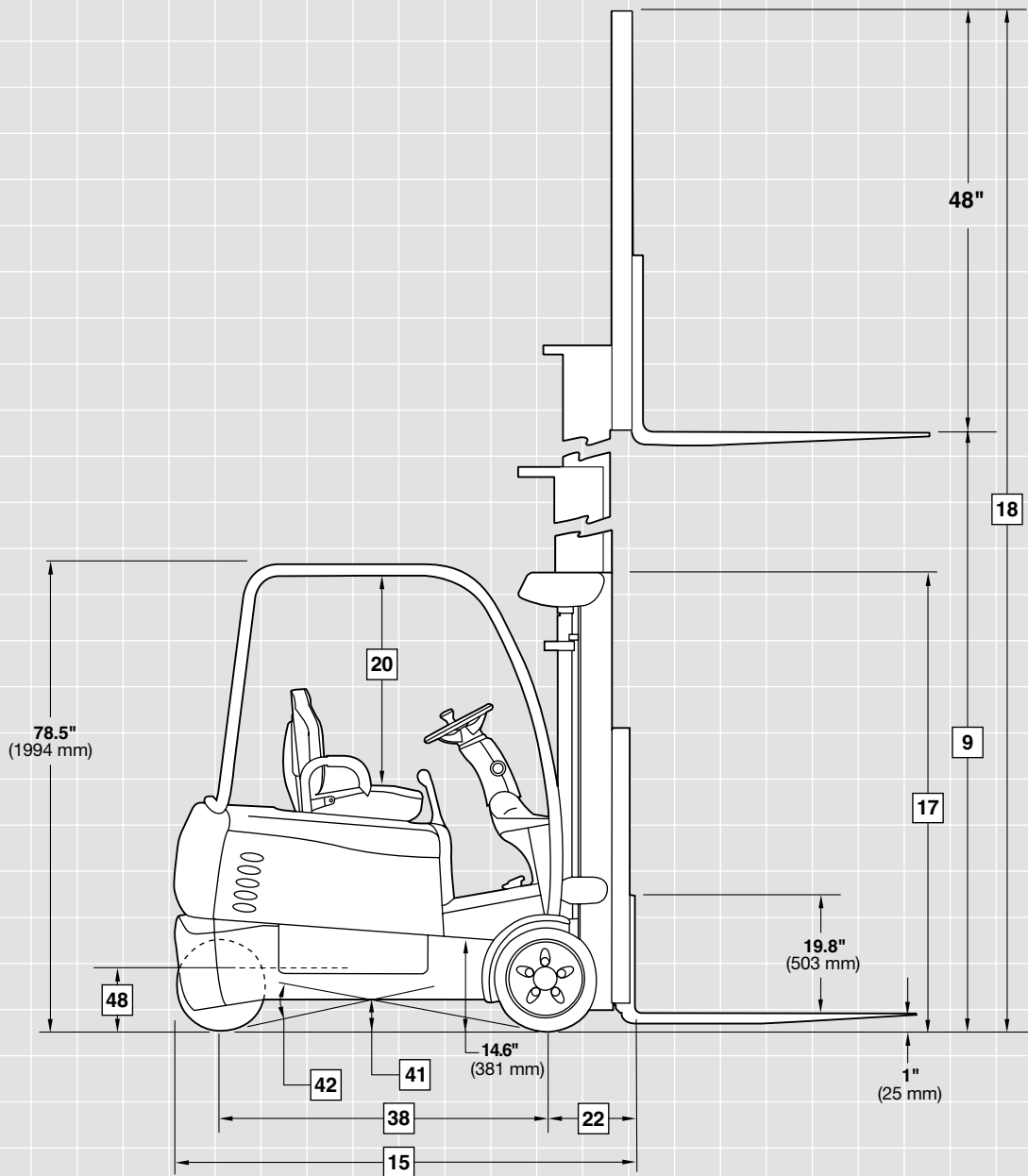
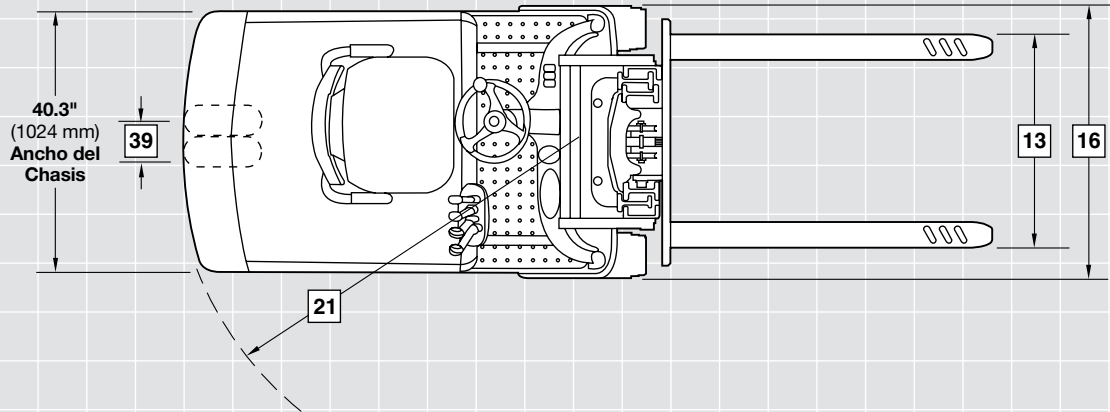

SC 5200 Series

Specifications

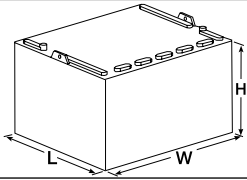
			Imperial	Metric	Imperial	Metric	Imperial	Metric					
General Information	1	Manufacturer	Crown Equipment Corporation										
	2	Model	SC		521X-30		522X-30		522X-35				
	3	Load Capacity*	Rated to 154" (3911 mm)	lb kg	3000	1361	3000	1361	3500	1588			
	4	Load Center	Fork Face to Load CG	in mm	24	600	24	600	24	600			
	5	Power	Electric										
	6	Operator Type	36/48 Volts Sit-down Rider										
	7	Tire Type	Press-on Solid Cushion										
	8	Wheels (x = driven)	Number Front/Rear 2x/2										
Dimensions	9	Mast**	Lifting Height	in mm	190	4825	190	4825	190	4825			
	11		Free Lift Height†	in mm	35	885	35	885	35	885			
	12	Fork Carriage	ITA Class II										
	13	Forks	Standard L x W x T	in mm	36x4x1.5	915x102x38	36x4x1.5	915x102x38	36x4x1.75	915x102x45			
			Optional Lengths	in mm	30, 39, 42, 45, 48, 54, 60, 63, 72	760, 990, 1065, 1145, 1220, 1370, 1525, 1600, 1830	30, 39, 42, 45, 48, 54, 60, 63, 72	760, 990, 1065, 1145, 1220, 1370, 1525, 1600, 1830	30, 32, 39, 40, 42, 43.31, 45, 48, 54, 60, 72	760, 815, 990, 1015, 1065, 1100, 1145, 1220, 1370, 1525, 1830			
			Fork Spread—Min/Max	in mm	9/33	230/840	9/33	230/840	9/33	230/840			
	14	Tilt	B°/F°	degree	5/5								
	15	Headlength***			68.5	1740	72.8	1849	73.0	1854			
	16	Width Overall	Standard Tread	in mm	42.0	1067	42.0	1067	42.0	1067			
	17	Height	Mast Collapsed	in mm	83	2110	83	2110	83	2110			
	18		Mast Extended†	in mm	238	6045	238	6045	238	6045			
	20	Seat to Bottom of OHG Clearance (Loaded)	Std / Suspension	in mm	39.06/38.69	992/982	39.06/38.69	992/982	39.06/38.69	992/982			
21	Turning Radius			54.2	1377	58.5	1486	58.5	1486				
22	Load Distance***	Wheel Cntr to Fork Face	in mm	14.3	365	14.3	365	14.5	370				
23	Aisle Width	Right Angle Stack	in mm	Turn Radius + Load Distance + Load Length + Clearance									
Performance	24a	Speed Travel††	36V	Empty/Loaded	mph mm/s	8.5/7.6	3800/3398	8.5/7.6	3800/3398	8.5/7.6	3800/3398		
	24b		48V	Empty/Loaded	mph mm/s	9.5/8.9	4247/3979	9.5/8.9	4247/3979	9.5/8.9	4247/3979		
	25a	Speed Lift††	36V DC	Empty/Loaded	fpm mm/s	90/63	457/320	90/63	457/320	90/60	457/305		
	25b		36V AC	Empty/Loaded	fpm mm/s	110/72	559/366	110/72	559/366	110/69	559/351		
	25c		48V AC	Empty/Loaded	fpm mm/s	110/77	559/391	110/77	559/391	110/75	559/381		
	26a	Speed Lower	Manual	Empty/Loaded	fpm mm/s	90/90	457/457	90/90	457/457	90/90	457/457		
26b	EPV		Empty/Loaded	fpm mm/s	100/100	508/508	100/100	508/508	100/100	508/508			
Weight	32	Weight, Less Battery			6149	2790	5974	2710	6216	2820			
	33	Axle Load with Max Battery	Unloaded Front	lb kg	4047	1835	4300	1950	4316	1960			
	34		Unloaded Rear	lb kg	3852	1745	3924	1780	4150	1880			
Chassis	35	Tires	Number Front/Rear		2/2								
	36		Size Front	in mm	18x7x12.1	457x178x307	18x7x12.1	457x178x307	18 x 7 x 12.1	457x178x307			
	37		Size Rear	in mm	15x5x11.25	381x127x286	15x5x11.25	381x127x286	15x5x11.25	381x127x286			
	38	Wheelbase			46.2	1173	50.5	1283	50.5	1283			
	39	Tread Width	Front	in mm	35.0	889	35.0	889	35.0	889			
			Rear	in mm	6.7	170	6.7	170	6.7	170			
	40	Ground Clearance, Loaded	Lowest Point	in mm	3.0	76	3.0	76	3.0	76			
	41		Center of Wheelbase	in mm	4.8	122	5.0	127	5.0	127			
	42	Grade Clearance, Loaded			27.1		24.6		24.6				
	43	Brakes	Service		Foot - Motor / Electric Assist								
44	Parking		Auto - Electric										
Battery	45	Battery	Type		Lead Acid								
	46		Capacity		AH		510		680		680		
					kWh		17.8		23.7		23.7		
			Weight - Min		lb kg	1475	670	1850	840	1850	840		
			Weight - Max		lb kg	1750	795	2250	1025	2250	1025		
			Size - Max		Length	16.63	422	20.87	530	20.87	530		
			Width	38.81	986	38.81	986	38.81	986				
		Height	22.63 †††	579 †††	22.63 †††	579 †††	22.63 †††	579 †††					
48	Battery Floor Height	With Rollers/ w/o Rollers		in mm		10.4/9.8		264/249		10.4/9.8		264/249	
Motors	49	Motors	Traction Motor, dia	in mm	7.5	191	7.5	191	7.5	191			
	50		Lift Motor, dia	in mm	6.7	170	6.7	170	6.7	170			
51	Operating Pressure	For Attachments	psi bar	Up to 3100	Up to 214	Up to 3100	Up to 214	Up to 3100	Up to 214				

* Optional masts, attachments, longer load dimensions and higher lifting heights may result in derating of the capacity. Contact your local dealer.

** Other mast heights available. See chart for other standard mast heights.

*** Add 4.25" (108 mm) for quad masts, add 2" (51 mm) for sideshift option.

† Includes load backrest.

†† Performance specifications are based on a truck equipped with a 190" (4825 mm) triple telescopic mast.

††† Without Battery Comp't Rollers - Max battery height is 23.29" (592 mm) at the battery center lifting eye and 22.63" (575 mm) at the battery front corner.
With Battery Comp't Rollers - Max battery height is 22.80" (579 mm) at the battery center lifting eye and 22.14" (562 mm) at the battery front corner.

SC 5200 Series

Specifications

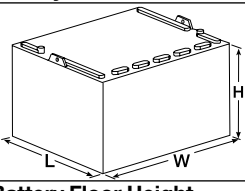
			Imperial	Metric	Imperial	Metric	
General Information	1	Manufacturer	Crown Equipment Corporation				
	2	Model	SC	524X-35	524X-40		
	3	Load Capacity*	Rated to 154" (3911 mm) lb kg	3500	1588	4000	1814
	4	Load Center	Fork Face to Load CG in mm	24	600	24	600
	5	Power	Electric	36/48 Volts			
	6	Operator Type		Sit-down Rider			
	7	Tire Type	Press-on Solid	Cushion			
	8	Wheels (x = driven)	Number Front/Rear	2x/2			
Dimensions	9	Mast**	Lifting Height in mm	190	4825	190	4825
	11		Free Lift Height† in mm	35	885	35	885
	12	Fork Carriage		ITA Class II			
	13	Forks	Standard L x W x T in mm	36x4x1.75	915x102x45	36x4x1.75	915x102x45
			Optional Lengths in mm	30, 32, 39, 40, 42, 43.31, 45, 48, 54, 60, 72	760, 815, 990, 1015, 1065, 1100, 1145, 1220, 1370, 1525, 1830	30, 32, 39, 40, 42, 43.31, 45, 48, 54, 60, 72	760, 815, 990, 1015, 1065, 1100, 1145, 1220, 1370, 1525, 1830
			Fork Spread—Min/Max in mm	9/33	230/840	9.5/36	240/915
	14	Tilt	B°/F° degree	5/5			
	15	Headlength***	in mm	77.2	1960	77.2	1960
	16	Width Overall	Standard Tread in mm	42.0	1067	42.0	1067
	17	Height	Mast Collapsed in mm	83	2110	83	2110
			Mast Extended† in mm	238	6045	238	6045
	20	Seat to Bottom of OHG Clearance (Loaded)	Std / Suspension in mm	39.06/38.69	992/982	39.06/38.69	992/982
	21	Turning Radius	in mm	62.7	1595	62.7	1595
	22	Load Distance***	Wheel Cntr to Fork Face in mm	14.5	370	14.5	370
23	Aisle Width	Right Angle Stack in mm	Turn Radius + Load Distance + Load Length + Clearance				
Performance	24a	Speed Travel††	36V Empty/Loaded mph mm/s	8.5/7.6 3800/3398	8.5/7.6 3800/3398	8.5/7.6 3800/3398	
	24b	48V Empty/Loaded mph mm/s	9.5/8.9 4247/3979	9.5/8.9 4247/3979	9.5/8.9 4247/3979		
	25a	Speed Lift††	36V DC Empty/Loaded fpm mm/s	90/60 457/305	90/58 457/295	90/58 457/295	
	25b	36V AC Empty/Loaded fpm mm/s	110/69 559/351	110/67 559/340	110/67 559/340		
	25c	48V AC Empty/Loaded fpm mm/s	110/75 559/381	110/73 559/371	110/73 559/371		
	26a	Speed Lower	Manual Empty/Loaded fpm mm/s	90/90 457/457	90/90 457/457	90/90 457/457	
26b	EPV Empty/Loaded fpm mm/s	100/100 508/508	100/100 508/508	100/100 508/508			
Weight	32	Weight, Less Battery	lb kg	6040 2740	6260 2840	6260 2840	
	33	Axle Load with Max Battery	Unloaded Front lb kg	4518 2050	4506 2845	4506 2845	
	34		Unloaded Rear lb kg	4122 1870	4355 1975	4355 1975	
Chassis	35	Tires	Number Front/Rear	2/2			
	36		Size Front in mm	18x7x12.1 457x178x307	18x7x12.1 457x178x307	18x7x12.1 457x178x307	
	37		Size Rear in mm	15x5x11.25 381x127x286	15x5x11.25 381x127x286	15x5x11.25 381x127x286	
	38	Wheelbase	in mm	54.7 1390	54.7 1390	54.7 1390	
	39	Tread Width	Front in mm	35.0 889	35.0 889	35.0 889	
			Rear in mm	6.7 170	6.7 170	6.7 170	
	40	Ground Clearance, Loaded	Lowest Point in mm	3.0 76	3.0 76	3.0 76	
			Center of Wheelbase in mm	5.0 127	5.0 127	5.0 127	
42	Grade Clearance, Loaded	%	22.4	22.4	22.4		
43	Brakes	Service	Foot - Motor / Electric Assist				
44		Parking	Auto - Electric				
Battery	45	Battery	Type	Lead Acid			
	46		Capacity AH	850	850	850	
			kWh	29.6	29.6	29.6	
	47	Weight - Min lb kg	2250 1025	2250 1025	2250 1025		
			Weight - Max lb kg	2600 1180	2600 1180	2600 1180	
			Size - Max Length	25.13 638	25.13 638	25.13 638	
Width			38.81 986	38.81 986	38.81 986		
	Height	22.63 ††† 579 †††	22.63 ††† 579 †††	22.63 ††† 579 †††			
48	Battery Floor Height	With Rollers/ w/o Rollers in mm	10.4/9.8 264/249	10.4/9.8 264/249	10.4/9.8 264/249		
Motors	49	Motors	Traction Motor, dia in mm	7.5 191	7.5 191	7.5 191	
			Lift Motor, dia in mm	6.7 170	6.7 170	6.7 170	
	50	Operating Pressure	For Attachments psi bar	Up to 3100 Up to 214	Up to 3100 Up to 214	Up to 3100 Up to 214	

* Optional masts, attachments, longer load dimensions and higher lifting heights may result in derating of the capacity. Contact your local dealer.
 ** Other mast heights available. See chart for other standard mast heights.
 *** Add 4.25" (108 mm) for quad masts, add 2" (51 mm) for sideshift option.
 † Includes load backrest.
 †† Performance specifications are based on a truck equipped with a 190" (4825 mm) triple telescopic mast.
 ††† Without Battery Comp't Rollers - Max battery height is 23.29" (592 mm) at the battery center lifting eye and 22.63" (575 mm) at the battery front corner.
 With Battery Comp't Rollers - Max battery height is 22.80" (579 mm) at the battery center lifting eye and 22.14" (562 mm) at the battery front corner.

Mast Chart SC 5200 Series		TF				TT									
		in	mm	in	mm	in	mm	in	mm	in	mm	in	mm		
9	Lifting Height	114	2895	126	3200	172	4365	190	4825	208	5280	226	5740	241	6120
11	Free Lift Height*	29	735	35	889	29	735	35	885	41	1040	47	1190	52	1320
14	Tilt B/F (degree)	5/5**	5/5**	5/5**	5/5**	5/5	5/5	5/5	5/5	5/5	5/5	3/5	3/5	3/5	3/5
17	Mast Collapsed Height	77	1955	83	2110	77	1955	83	2105	89	2260	95	2410	100	2540
18	Mast Extended Height*	162.5	4130	174.5	4430	220.5	5605	238.5	6060	256.5	6515	274.5	6975	289.5	7355

Mast Chart SC 5200 Series		QUAD									
		in	mm	in	mm	in	mm	in	mm		
9	Lifting Height	240	6095	246	6245	258	6550	264	6705	276	7010
11	Free Lift Height*	36	910	38	965	41	1040	44	1115	47	1190
14	Tilt B/F (degree)	5/5**	5/5**	3/5**	3/5**	3/5**	3/5**	3/5**	3/5**	3/5**	3/5**
17	Mast Collapsed Height	83	2105	86	2180	89	2260	92	2335	95	2410
18	Mast Extended Height*	288	7315	294	7470	306	7775	312	7925	324	8230

* Includes load backrest.

** Not available with drive-in rack or double-function hydraulics.

SC 5200 Series

Technical Information

Standard Equipment

- Crown's Access 1 2 3[®] Comprehensive System Control
- e-GEN[®] Braking System with automatic parking brake
- Intrinsic Stability System[®]
 - Travel speed reduction and appropriate brake control when forks are above free lift
 - Forward tilt interlock above free lift
 - Controlled tilt speeds
 - Counterweight exceeds required standards
 - Cornering speed control
 - Ramp hold
 - Ramp speed control
- 36/48-volt system
- Driveability standard features
 - 15" (381 mm) step height
 - Large, uncluttered floorboard
 - Rubber floor mat
 - Rubber accelerator and brake pedal
 - Large, entry/exit "window"
 - Contoured battery cover for easy entry/exit
 - Crown FlexSeat™ - fabric with hip restraint and anti-cinch seatbelt
 - Compact steering wheel and steering column

- Infinitely adjustable tilt steering
 - Operator forward design for enhanced visibility
 - Low cowl for fork and floor visibility
 - Nylon covered manual hydraulic control levers with integrated tactile feedback
 - Natural position for forward/reverse selector
 - Automatic parking brake
 - Crown FlexSeat with a passive suspension and back flex
- Crown display
 - Battery discharge indicator with lift interrupt and re-key feature
 - Hour meters / travel distance / stop watch
 - Pin code access capable
 - Event code display with five (5) key navigation
 - Access 1 2 3 diagnostics
 - P1, P2, P3 Performance tuning
 - 350 amp battery connector
 - InfoPoint[®] System with Quick Reference Guide
 - Color-coded wiring
 - Lift out or side removal battery access
 - Dual 15" (381 mm) steer tires
 - Large 18" (457 mm) cushion drive tires

- Crown-manufactured drive and lift motors
- Proportional rack and pinion steering
- Waterfall design overhead guard
- 48" (1220 mm) high load backrest
- No tool lift out floorboards for service access
- High visibility mast with in-line hose routing
- O-ring face seal hydraulic fittings
- 5° Forward / 5° Back tilt
- All AC System
- On-Demand Steering
- Drive Axle Debris Guard

Optional Equipment

- Battery rollers
- Quick Charge 1 or 2 connectors on seat deck
- Freezer and corrosion conditioning
- Sideshifter
- Hydraulic valves for attachments
- Quick disconnect hydraulic connectors
- Steering spinner knob
- Storage tray
- Keyless on/off switch

- Keypad lock
- Foot operated directional control
- Fork lengths
- Polished and tapered forks
- Load backrest heights
- Super elastic tires
- Drive-in rack overhead guard
- 83" overhead guard
- Tilt options
- Working lights
- Flashing lights
- Turn signals
- Brake, tail and back-up light
- Audible travel alarms
- Tilt position assist
- Arm rest
- Grabbar
- Work Assist[®] Accessories
 - Clip pad and hook
 - Clamp
 - Clamp and mounting plate
 - Operator fan
 - Fire extinguisher
 - Mirrors
 - Shrink Wrap Holder
 - Cup Holder
 - Pencil Holder
 - Storage pocket behind seat

- 28. Suspension Seat - fabric or vinyl
- 29. Crown FlexSeat - vinyl
- 30. Rear Post Handle with Horn Button
- 31. Hydraulic control options with directional travel and horn integrated into the adjustable armrest
 - Fingertip control levers
 - Dual-axis joystick control levers

Driveability

The SC 5200 Series benefits from Crown's design and engineering excellence. Numerous design features improve operator comfort and productivity.

A low 15" (381 mm) step height first greets the operator. A low battery cover that is streamlined helps the operator glide into the truck's Crown FlexSeat™. The overhead guard is shaped to open up the entry/exit window. The compact tilt steer column and steer wheel further facilitate entry/exit. Floorboards are large, uncluttered and rubber covered to insulate the operator from vibration. Brake and accelerator pedals are rubber covered to provide good grip and comfort.

Several designs contribute to better visibility everywhere you look. A low cowl for fork visibility, a unique waterfall overhead guard for load handling, a high visibility mast and a compact steer column all improve operator visibility around the truck.

Control handles are crafted into the compartment and "fanned" for easy selection. They are nylon covered with tactile feedback for comfort and easy selection. Control actuation forces are minimal and responsive.

Crown Drive System

Crown has applied the latest generation AC drive system, enhanced with Access 1 2 3 technology. The demand for high efficiency systems that closely match customer torque requirements is met with this generation control system. Crown-manufactured, independently controlled, AC drive motors are specifically designed to optimize system integration between the traction and braking controls.

Crown's Access 1 2 3 technology provides optimum performance and control by offering a communication interface for

operators and technicians, intelligent coordination of lift truck system and simplified service with advanced diagnostics.

The Crown display is used for easy troubleshooting, access service history and set performance features. Three modes of performance can be selected to accommodate operator experience or application requirements.

e-GEN® Braking System

Variable regenerative motor braking is optimized and assisted with electric friction brakes, eliminating maintenance associated with typical wet, disk or drum and shoe style brakes. The appropriate amount of stopping force is applied to match operator brake input and the current operating conditions of the truck.

The closed loop Access 1 2 3 traction control will keep the truck static until a travel input is requested, even when operating on a grade.

Automatic electric parking brakes activate when the operator leaves the seat, a travel input has not been requested or battery power has been disconnected.

Proportional Rack and Pinion Steering System

Hydrostatic power steering uses a large, totally enclosed rack and pinion gear assembly. Load-sense hydrostatic steering is an on-demand system which reduces energy consumption. Smooth, quiet steering control with minimal operator effort required at the steer tiller. Crown's hydrostatic steering system is simplified with significantly fewer parts, thus reducing maintenance requirements.

The steering geometry is matched to the controller to deliver smooth steering at all angles. The advantage is less tire scrubbing which extends tire life.

Both motors receive power, even in the tightest turns. This helps the truck to accelerate, turn and maneuver even from a full turn start position.

Cornering speed control regulates the drive motor's output by the turning degree of the truck. The advantage is smooth, stable steering which may increase operator confidence and productivity.

SC 5200 Series

Large, (15" diameter, 381 mm) dual steer wheels provide good traction and stability.

Hydraulics

The hydraulic system provides continuous filtration. A heat stabilized polymer hydraulic tank is free from contamination and retains strength over a wide range of temperatures. Hydraulic attachments can be added easily in the field using modular valve bodies. Hydraulic valve handle actuation is precise and oil is controlled using metered spool valves and motor speeds.

Ram displacement type lift cylinders and two double acting tilt cylinders are Crown-manufactured. All rams and piston rods are hard chrome plated to reduce pitting and extend cylinder packing life. O-ring face seal fittings are used to eliminate leaks.

Mast Assembly

Crown-manufactured mast assembly utilizes a "flush-face" interlocked I-beam design to improve visibility and save truck length. Roller bearing studs are welded on both sides of the rails for maximum strength and roller bearings are canted to run in the thick cross section of the rail. Tie bars wrap around the rails for added strength and to resist off-center load forces.

"In-line" hose routing opens up visibility. Cylinders are placed to the sides to create a high visibility design.

The mast has four points of attachment to the truck for good load force distribution. Two mounting points are at the frame, where tilt cylinders attach. Tilt cylinders use spherical bushings to resist off center load

Technical Information

distortions. Two large diameter studs secure the mast to the drive units.

Drive Units

Two Crown-manufactured independent double reduction planetary gear drives offer 27 to 1 gear reduction. The first and second reduction use helical gears for low noise and efficiency. The drive unit gears are splash lubricated in an oil bath.

Carriage

An ITA Class II carriage is standard. An optional hook type ITA sideshifter or other attachments are easily added. Optional fork lengths are available.

Other Options

1. Audible travel alarm
2. Flashing lights

Safety considerations and dangers associated with audible travel alarms and flashing lights include:

- Multiple alarms and/or lights can cause confusion.
- Workers ignore the alarms and/or lights after day-in and day-out exposure.
- Operator may transfer the responsibility for "looking out" to the pedestrians.
- Annoys operators and pedestrians.

Other Options Available

Contact your local Crown dealer.

Dimensions and performance data given may vary due to manufacturing tolerances. Performance is based on an average size vehicle and is affected by weight, condition of truck, how it is equipped and the conditions of the operating area. Crown products and specifications are subject to change without notice.



You can count on Crown to build lift trucks designed for safe operation, but that's only part of the safety equation. Crown encourages safe operating practices through ongoing operator training, safety-focused supervision, maintenance and a safe working environment. Go to crown.com and view our safety section to learn more.

Crown Equipment Corporation

New Bremen, Ohio 45869 USA
 Tel 419-629-2311
 Fax 419-629-3796
crown.com

Because Crown is continually improving its products, specifications are subject to change without notice.

Crown, the Crown logo, the color beige, the Momentum symbol, Access 1 2 3, InfoPoint, e-GEN, Intrinsic Stability System, FlexSeat and Work Assist are trademarks of Crown Equipment Corporation.

Copyright 2011-2016 Crown Equipment Corporation
 SF14690 Rev. 12-16
 Printed in U.S.A.